

# CIMCO PROBING

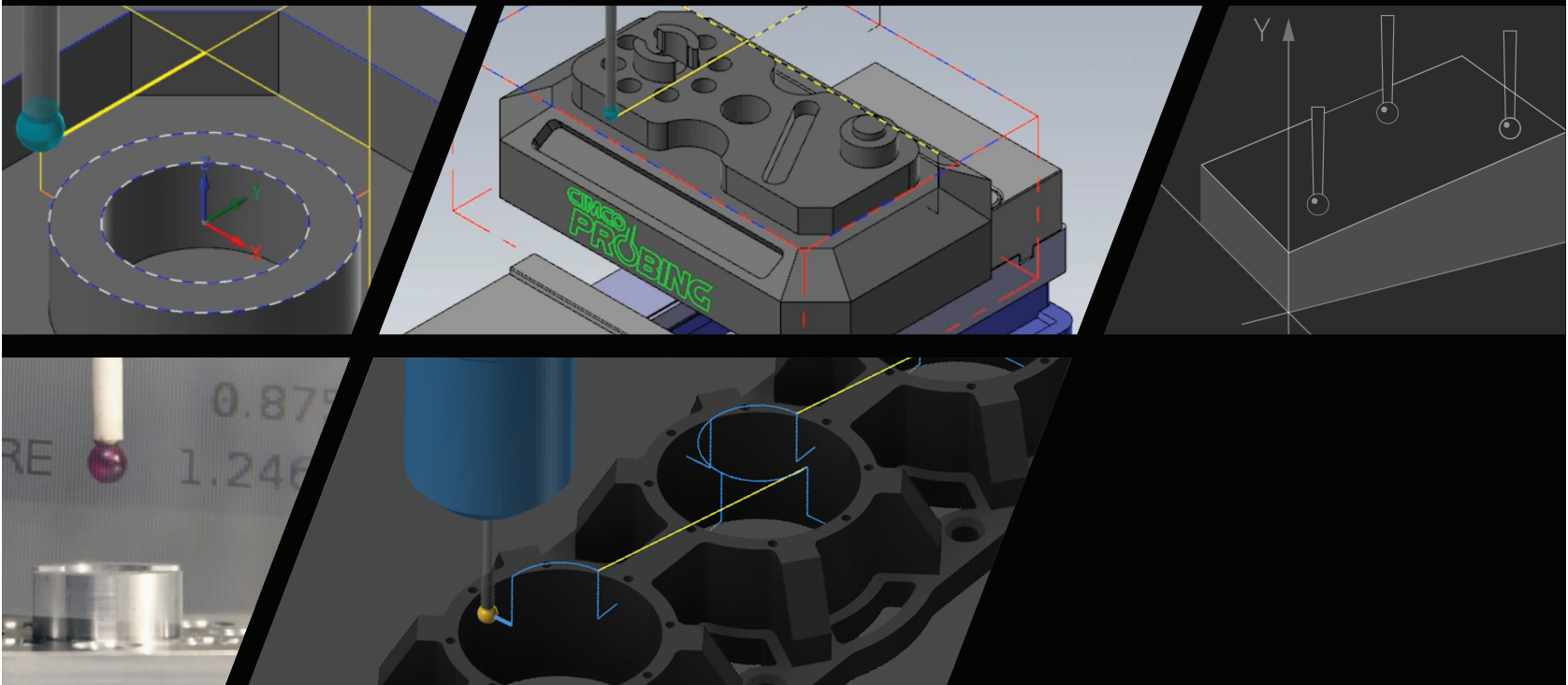

## INTEGRATED PROBING SOLUTION FOR MASTERCAM

# UNLOCK THE FULL POTENTIAL OF YOUR CNC TOUCH PROBE

Program CNC touch probes from different vendors such as Heidenhain and Renishaw directly in Mastercam

CIMCO Probing is a fully integrated add-on for Mastercam that makes probing a natural part of the Mastercam programming process. Program your touch probe the same way you program toolpaths. CIMCO Probing generates recognizable and easy-to-understand NC-code by letting you use the cycles and macros already available on your CNC machines.

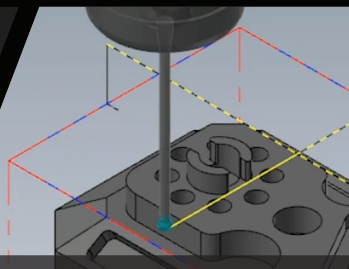

Visualize and verify movement  
Backplot, Verify and Machine



Includes a wide range of predefined and fully customizable probe cycles



Create cycles directly off the same CAD model used for toolpathing

## WORKS WITH POPULAR BRANDS

CIMCO Probing works with popular CNC probe brands such as Renishaw, Blum-Novotest and Heidenhain.

## CREATE CYCLES FROM CAD MODEL

Program probing cycles directly off the same CAD model used for toolpathing and other Mastercam operations. Full associativity ensures the probepath is updated with geometry changes.

## PREDEFINED PROBE CYCLES

Includes a wide range of predefined and fully customizable probe cycles for most measurement needs. Point at any cycle parameter and a dynamic diagram shows exactly what the parameter controls.

## INSPECT

All probe movements can be conveniently visualized and verified using Mastercam's Backplot, Verify and Machine Simulation. Ensure that your probe tool remains undamaged during machining. Probe tool collisions can be detected and resolved before the program is machined.

## USER-FRIENDLY INTERFACE

As a fully integrated add-on, CIMCO Probing will be familiar and intuitive to any Mastercam user. Full access to standard right-click menus, Auto-cursor selection tools and mouse wheel scrolling for easy changes.

## MULTI-LANGUAGE SUPPORT

CIMCO Probing is available in English and German. Support for more languages is on the roadmap.

## LOCALIZED SUPPORT NETWORK

CIMCO Probing is offered through Mastercam resellers worldwide who provide the highest level of service to customers in their local language and time zone.

## CONTINUOUS IMPROVEMENT

CIMCO Probing is actively being developed and new versions, including new functionality, are released at short intervals.

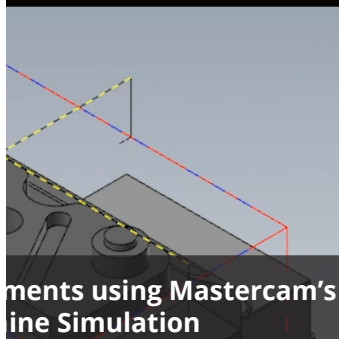

Simulations using Mastercam's line Simulation

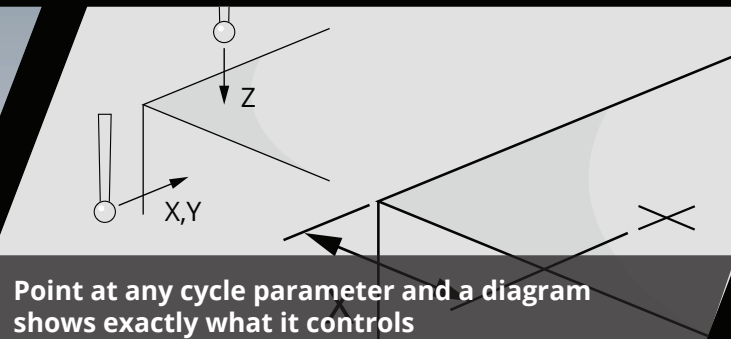

Point at any cycle parameter and a diagram shows exactly what it controls

```
G1.001  
G154 P10 X0. Y0. M5  
Z1.  
P32  
P810 X0. Y0. Z1. F50.  
P9810 Z-.3681  
P9814 D1. Q.125 S154.10  
P9810 Z1.  
P9833  
M0 = #188 (ACTUAL: DIAMETER)  
M01 = #193 (DEVIATION: DIAMETER)  
SET G154P10)  
G187 P3 E.001  
G154 P10 X0. Y0. Z1.  
G65 P9832
```

UNLOCK THE FULL POTENTIAL  
OF YOUR CNC TOUCH PROBE WITH

# THE FULL SUITE OF CIMCO PRODUCTS

## CIMCO VERIFY

Validate your tool and probe paths using CIMCO's accelerated simulation kernel.

## EDIT INTEGRATION

Transfer posted code, tools, holders, workpiece, fixture and stock directly from Mastercam to CIMCO Edit.

## CIMCO MACHINE SIMULATION

Import, prove out and run your post processed code all while checking for collisions against vital components of your machine and its travel limits.

## CIMCO MDM

Organize, manage and access all of your manufacturing documents such as Mastercam part files, NC G-code, setup sheets, tool lists, and probing report data from anywhere.

## CIMCO DNC-MAX

Transfer your post processed Mastercam code files back and forth directly to your CNC Machines. Collect probing report data or edits made to your program.

## CIMCO MDC-MAX

Real time monitoring of machines uptime, downtime, status, and alarms. Receive notifications on status events happening on your machine instantly.

RENISHAW  
 BLUM-NOVOTEST  
 HEIDENHAIN  
 SIEMENS  
 OKUMA  
 HAAS  
 FANUC  
 BROTHER  
 MAZAK  
 MITSUBISHI  
 MAKINO  
 AND MORE...



**PROBING.COM**

**DOWNLOAD YOUR FREE TRIAL TODAY**

Experience CIMCO Probing first hand. Visit [probing.com](http://probing.com) to request a free trial license, download the latest version and learn how to master CIMCO Probing.

**MAIN OFFICES**

**DENMARK** CIMCO A/S  
 VERMUNDSGADE 38A  
 COPENHAGEN, DENMARK

TEL: +45 45 85 60 50  
 FAX: +45 45 85 60 53  
 EMAIL: [info@cimco.com](mailto:info@cimco.com)

**AMERICAS** CIMCO AMERICAS, LLC  
 1980 N ATLANTIC AVE STE 229  
 COCOA BEACH, FL 32931

TEL: +1 704 644 3587  
 TEL: +1 704 943 0514  
 FAX: [info@cimco.com](mailto:info@cimco.com)



CIMCO HEADQUARTERS AND MAIN TRAINING FACILITY ARE LOCATED IN THE DANISH CAPITAL COPENHAGEN. THIS IS THE BASE OF OPERATION FOR THE SALES AND SUPPORT TEAM. OUR TECHNICAL SERVICE STAFF TRAVELS WORLDWIDE AND HAS LOCAL OFFICES IN SELECT COUNTRIES.



More information at [www.cimco.com](http://www.cimco.com)



Watch our videos at [@cimcoveideo](https://www.youtube.com/@cimcoveideo)



Follow on Facebook [/cimco](https://www.facebook.com/cimco)



Follow on LinkedIn [/company/cimco-a-s](https://www.linkedin.com/company/cimco-a-s)